

GENERAL NOTES

- UNLESS OTHERWISE INDICATED ALL DIMENSIONS ARE IN mm.
- UNLESS OTHERWISE INDICATED ALL THICKNESS ARE NOMINAL.
- UNLESS OTHERWISE INDICATED ALL GIRTH FLANGES AND FLANGE CONNECTION BOLT HOLES MUST BE STAGGERED TO MAIN AXIS OF THE EQUIPMENT.
- UNLESS OTHERWISE INDICATED NOZZLE PROJECTION ARE MEASURED FROM EQUIPMENT CENTER LINE TO CONTACT FLANGE FACINGS.
- FLANGES ACC. TO ASME B16.5 ED. 2009, SEAMLESS PIPES ACC. TO ASME B36.10M LATEST EDITION, CAP ACC. TO ASME B16.9 LATEST EDITION, EXTERNAL GASKETS ACC. TO ASME B16.20 LATEST EDITION, STUD BOLTS WITH INCH THREAD ON THE WHOLE, HEAVY HEX NUTS, THREAD ACC. ASME B1.1
- ALL THICKNESS SHOWN IN THIS DRAWING ARE NOMINAL UNLESS OTHERWISE SPECIFIED.
- NOZZLE FLANGES CONTACT FACINGS SHALL BE: $Ra=3.2\pm 6.3\mu m$.
- ALL INTERNAL AND EXTERNAL PARTS WELDED TO THE SHELL SHALL BE SAME MATERIAL WHICH CONSTITUTES THE SECTION OF THE SHELL WHERE THE PARTS WILL BE WELDED, EXCEPT AS NOTED.
- CARBON STEEL EXTERNAL SURFACES SAND BLASTING SA 2,5 AND PAINTING WITH PRIMER, INORGANIC ZINC $75\mu m$.
- UNITS SELECTED FOR CONSTRUCTION: SI.
- MATERIALS EXEMPTED FROM IMPACT TEST ACCORDING TO ASME VIII div. 1 UG-20(f).
- HYDROTEST WITH WATER CONTAINING MAX. 250pp.m. OF CHLORIDES.
- FOR ALL REINFORCING PADS PROVIDE TWO 1/4" NPT ACC. ASME B1.20.1. THREADED HOLES. VENT PIPE SHALL BE FITTED TO THE HOLE AND PROTRUDE BEYOND THE INSULATION.
- FABRICATION TOLERANCES ACCORDING TO EN 13445-4 ANEX A.

REFERENCE DRAWINGS

DRAWING	TITLE	REV
2014-TEST-ASME-02	WELDS MAP	0
2014-TEST-ASME-03	BILL OF MATERIALS	0
2014-TEST-ASME-04	MACHANICAL CALCULATION REPORT	0
2014-TEST-ASME-05	SUPPORT CALCULATION REPORT	0

DESIGN DATA

No. OF REQUIRED: 1 (ONE)		SERIAL NUMBER: 1104	
CODE DESIGN	ASME VIII DIV. 1 ED. 2013	INSPECTION AND TESTING	ASME AUTHORIZED INSPECTOR & CLIENT
CERTIFICATION MARK WITH THE U DESIGNATOR	YES	X-RAY EXAMINATION	RT3 (SPOT)
NATIONAL BOARD REGISTRATION	NO	LIQUID PENETRANT	NONE
SERVICE	N.A.	MT EXAMINATION	NONE
JOINT EFFIC. SHELL/HEAD	0,85 / 0,85	UT EXAMINATION	NONE
CORROSION	mm 3	LT EXAMINATION	NONE
TYPE	INDUSTRIAL WATER	POST WELD HEAT TREATMENT	NO
PHYSICAL STATE	LIQUID	MILL MATERIALS CERTIFICATES	-
SPECIFIC WEIGHT	kg/m ³ 1000	PRODUCTION TEST COUPONS	NO
LETHAL SERVICE	NO	IMPACT TEST	NO
INTERNAL DESIGN PRESSURE	kPa(g) 600	INSULATION	mm NO
EXTERNAL DESIGN PRESSURE	kPa(g) -	SHOP PAINTING	NOTE 10
TEST PRESSURE	kPa(g) 780	WIND LOAD (basic)	NO
MAXIMUM ALLOWABLE WORKING PRESSURE	kPa(g) 600	EARTHQUAKE	N.A.
MAXIMUM ALL EXTERNAL WORKING PRESSURE	kPa(g) -	SNOW LOAD	kg/m ² N.A.
WORKING PRESSURE	kPa(g) 500	EMPTY WEIGHT	kg 140
DESIGN TEMPERATURE	°C 50	FULL WATER WEIGHT	kg 180
MINIMUM DESIGN METAL TEMPERATURE	°C 0 AT 600kPa(g)	WEIGHT OF INTERNALS	kg -
WORKING TEMPERATURE	°C 30	OPERATION WEIGHT	kg 170
MIN WATER TEMPERATURE DURING HYDROTEST (SEE NOTE 13)	°C 17+48	CAPACITY	m ³ 0,038
VALUES OF m	3		
VALUES OF Y	N/mm ² 69		
SIDE OF EQUIPMENT	SHELL	SIDE OF EQUIPMENT	SHELL

MATERIALS

PARTS	MATERIAL	ACCESSORIES	MATERIAL
SHELL	SA-333M Gr.6	GASKETS	ASME B16.20
HEAD	SA-420M Gr. WPL6	GASKETS	SPIRAL WOUND S.S. 304 GRAPHITE FILLED WITH S.S.304 INNER AND C.S. OUTER RING
NOZZLE FLANGES	SA-350M Gr. LF2 CL.1	NAME PLATE	STAINLESS STEEL
BLIND FLANGES	SA-350M Gr. LF2 CL.1	NAME PLATE SUPPORT	SA-516M Gr.415
NOZZLE PIPES	SA-333M Gr.6	EXT. PLATES WELDED TO SHELL	SA-516M Gr.415
REINFORCING PADS	SA-516M Gr.415		
BOLTS	SA-193 Gr. B7		
NUTS FOR NOZZLE CONN.	SA-194 Gr. 2H		

NOZZLES

MARK	Q.ty	NPS	CLASS	TYPE (1)	O.D.	Thk.	REINF. PAD O.D.xTHK.	PROJECTION	SERVICE
A	1	8	150	WN-RF	219,1	8,18	-	SEE DWG	INSPECTION (2)
B	1	3	150	WN-RF	88,9	5,49	170x8	265	INLET
C	1	3	150	WN-RF	88,9	5,49	170x8	265	OUTLET
D	1	2	150	WN-RF	60,3	5,54	-	210	DRAIN

- (1) NOZZLE FLANGES CONTACT FACINGS SHALL BE: $Ra=3.2\pm 6.3\mu m$ (AARH=125x250 μm).
 (2) WITH BLIND, BOLTING AND GASKET.

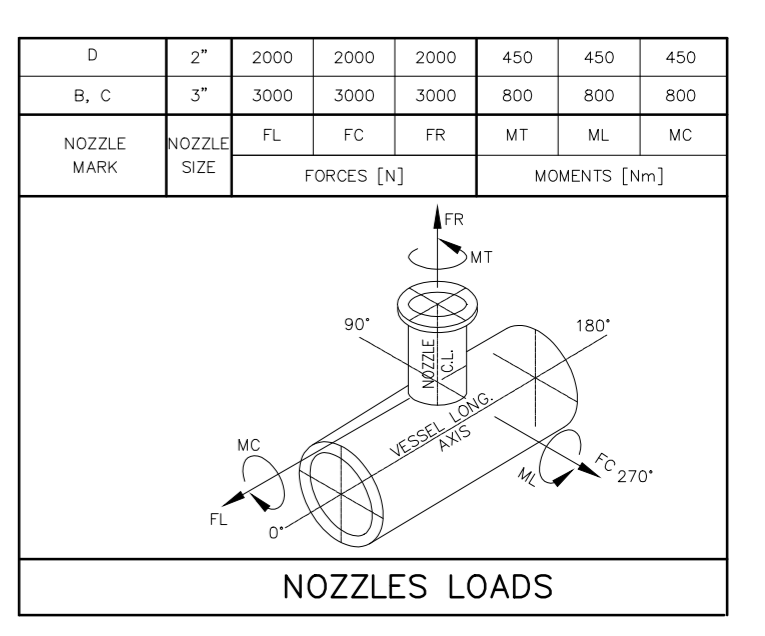

REV.	DATE	REVISION DESCRIPTION	DESIGN BY	APPROVED BY	ACCEPT BY
0	23.08.2014	ISSUE FOR CONSTRUCTION	P. Madej	J. Domanski	M. Gapiński

PROJECT NAME: DEMONSTRATION	Drawing Number: 2014-TEST-ASME-01	REVISION: 0
JOB No: 01/ASME/14	SCALE: 1:4	SIZE: A1

DOCUMENT TITLE: ASME DEMO TANK GENERAL ARRANGEMENT

THIS DOCUMENT IS IZOTECHNIK'S PROPERTY, AND CANNOT BE USED BY OTHERS FOR ANY PURPOSE, WITHOUT PRIOR WRITTEN CONSENT